



Affiliations

Department of Electronics
All India Institute of Speech and
Hearing, Mysuru

Corresponding Author

Dr. Ajish K. Abraham
Professor in Electronics and
Acoustics, Department of
Electronics
Email: ajish68@aiishmysore.in

Key Words

Noise reduction
Wavelet based
Modulation based
Multichannel Wiener filter
Blind source separation
Scene analysis

Abstract

Hearing the desired sound in presence of noise is the biggest challenge faced by a hearing aid user and hence is an area of great concern for the hearing aid designers as well as professionals. This paper reviews the noise reduction strategies currently implemented in hearing aids as well as those in the experimental stage, with an objective to precipitate the concerns and provide a clear direction to the developments further required. Techniques used for noise reduction in hearing aids are classified into two: noise reduction using microphones and the noise reduction through digital signal processing techniques. Noise reduction using two omni-directional microphones, three omni-directional microphones and adaptive beamforming techniques were reviewed under the first category. In the second category, signal processing techniques such as Wavelet Based noise reduction, Blind Source Separation, Modulation Based Digital Noise Reduction, Multichannel Wiener Filter, and Scene Analysis method were reviewed. On comparison, adaptive beamforming technique was found to be the most efficient one among the microphone based noise reduction strategies. Wavelet based noise reduction and Scene Analysis method were found to be the better signal processing techniques.

©JAIISH. All Rights Reserved

Background

Number of people living in this world with disabling hearing loss are estimated to be 360 million (World Health Organization [WHO], 2017). Hearing aid is the most widely used device for rehabilitation of these individuals (Dell'Antonia, Ikino, & Filho, 2013). With technological advancements in signal processing, overall satisfaction of a hearing aid user has increased from 74% in 2008 to 81% in 2014 (Abrams & Kihm, 2015). However, lowest satisfaction level of 50% was observed when the hearing aid users were trying to listen to a conversation in the presence of noise (Abrams & Kihm, 2015). Thus the problem of noise reduction in hearing aids continues to be a challenging task, despite the significant technological advancements.

Persons with sensorineural hearing loss have more difficulty in comprehending speech in noisy situations than people with normal hearing (Park, Moon, Jin, Choi, Cho, & Hong, 2015). Background noise is thus a problem of great concern for people with hearing impairment and thus noise reduction algorithms have significant role in hearing aid signal processing (Ngo, 2011). Hearing aid designers have been trying hard to develop techniques that enhances speech in comparison to noise for hearing aid users.

Levitt (2001) identified three types of noises encountered by hearing aid users that can affect speech intelligibility - random noise, other interfering voices, and reverberation. Interfering voices have the same spectrum as that of speech which makes it difficult to differentiate between the wanted and the unwanted signal.

Several techniques have been employed in hearing aids, over the years, to enhance the speech signal in comparison to noise. The focus of all these techniques was to make the speech intelligible to the user amidst background noise, and to enhance the quality of sound. Levitt (2001) reviewed the noise reduction techniques implemented in hearing aids till 2001 and outlined future developments required in this area. Chung (2004) reviewed the microphone technologies and noise reduction algorithms while pointing out the challenges in hearing aids. Bentler (2005) also reviewed the effectiveness of the noise reduction techniques which were implemented in hearing aids of those times. Other than these three reviews (Bentler, 2005; Chung, 2004; Levitt, 2001) no other reviews have been reported in the literature on this topic. Several techniques were implemented in the following years to improve the signal to noise ratio. Beck and Behrens (2016) opined that Digital Noise Reduction techniques which are currently implemented in the state of the art hear-

Table 1: Number of studies shortlisted under each category

Technique	Multiple Microphone based strategies			Signal processing based strategies				
				Currently implemented in hearing aids			Experimental stage	
	Two mic	Three mic	Beam-forming	MB-DNR	MWF	Scene Analysis	Wavelet Based	BSS
No. of selected studies	1	2	6	2	6	5	2	5

ing aids improve listening in noise. The purpose of this paper is to review the noise reduction techniques currently implemented in hearing aids and also which are in the experimental stage. To provide a clear direction to the developments further required, the following questions were considered in the systematic review: (a) Which noise reduction technique using multiple microphones provided better SNR? (b) Which signal processing technique provided better intelligibility?

Materials and Methods

Related studies were searched using the keywords such as “noise reduction strategies”, “hearing aids”, “processing of speech”, “noise control”, “speech enhancement”, “Directivity index”, “signal processing” etc. From 185 identified studies, studies were selected for detailed analysis based on the following criteria:

- a. Inclusion criteria :-
 - Studies pertaining to the noise reduction techniques classified by Ramirez, Jons, and Powers (2013)
 - Studies on techniques which resulted in improvement of SNR
 - Studies on techniques which improved the

speech intelligibility

b. Exclusion criteria :-

- Studies done by the hearing aid manufacturers on their specified models
- Studies done on manufacture specific Trade Mark software for noise control

Ramirez, Jons, and Powers (2013) classified the techniques used for noise reduction in hearing aids into two: noise reduction using microphones, and the noise reduction through digital signal processing techniques. Number of studies shortlisted based on the selection criteria and classified as per Ramirez, Jons, and Powers (2013) are indicated in the Table 1.

Noise Reduction Techniques

Noise reduction techniques using multiple microphones

Using two omnidirectional microphones

One technique implemented in hearing aids to reduce noise is to achieve direction-dependent sensitivity by taking the difference signal of two omnidirectional microphones placed in-line, one directed to the front of the user and the other one directed to the back. Figure 1 illustrates the technique where the output signal of the microphone M2 directed to the back is delayed and subtracted from the output signal of the front microphone M1. Bentler,

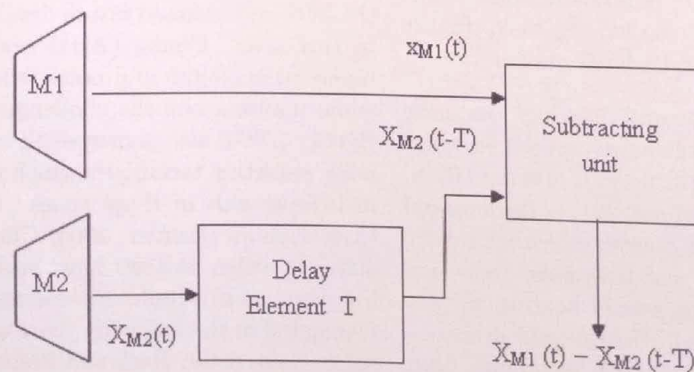

Figure 1: Noise reduction using two microphones

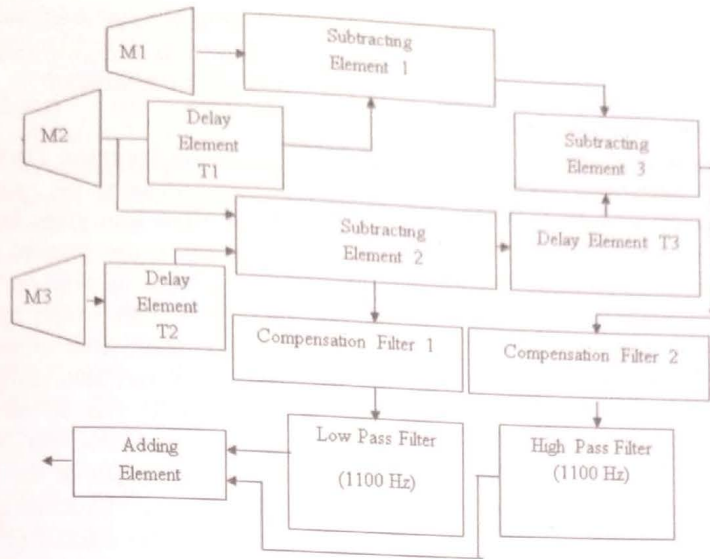

Figure 2: Noise reduction using three microphones

Palmer, and Dittberner (2004) reports a 3 dB improvement of SNR in moving noise and 4dB improvement in stationary noise when compared with a single microphone system.

Using three Omnidirectional microphones
 Subtracting element 2 compares the delayed signal of Microphone M3 and the direct signal of Microphone M2, as shown in Figure 2. Output of this comparison is fed to Subtracting element 3 along with the difference signal of M1 and M2. Outputs of Subtracting element 2 and 3 are added to get the final output where the noises picked up by M1, M2 and M3 would have cancelled out. The SNR improvement with a three microphone system, in theory, can be significantly higher than that of a two microphone system. A commercially available three microphone hearing aid (Siemens Triano-3)

claimed upto 7 dB directivity index as opposed to 4.3 dB for the two-microphone Triano-S (Powers and Hammacher, 2002)

Adaptive beamforming Beamforming is another technique for noise reduction where output signals of several microphones are processed to reduce noise. This is achieved by creating a constructive interference in a selected direction and destructive interference in non-selected directions. Processing may be a fixed or adaptive one resulting in fixed or adaptive beamforming respectively. In fixed beamforming time dependant transfer functions are used to process the output signals of each microphone as shown in Figure 3. In adaptive beamforming, at least one of the transfer functions is continuously modified for better noise reduction in the given environment (Kompis & Dil-

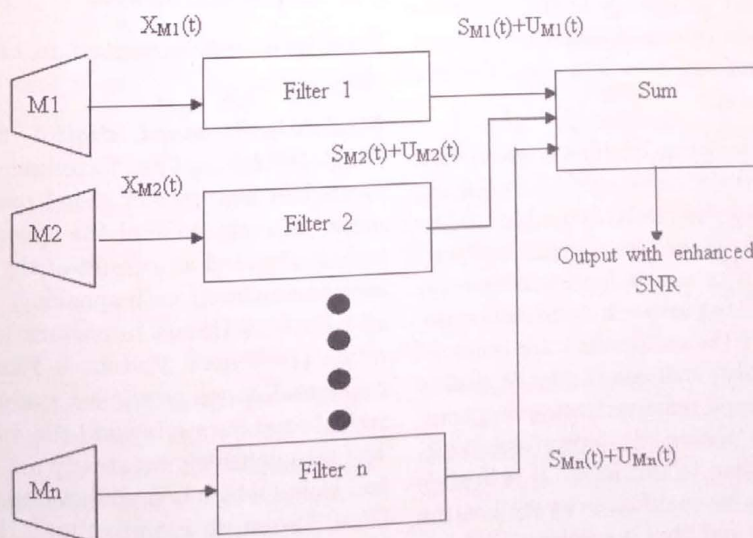

Figure 3: Noise reduction using fixed beam-forming

lier, 2001).

Adaptive beamformers can adapt to different noise situations and they can offer better noise reduction in most scenarios. The idea of beamforming as Generalized Sidelobe Canceller (GSC) algorithm was first implemented by Griffiths and Jim (1982). Their algorithm transforms the constrained optimization problem into an equivalent but simpler unconstrained optimization problem. Nishimura, Suzuki, Tsukui, and Asano (2004) proposed a method of beamforming which showed constraints to preserve perceptual cues at both ears in wide band Minimum Variance Distortionless Response (MVDR) beamformer. First beamformer for binaural hearing aids was developed by Lotter and Vary (2006) called super directive beamforming, which was based on a MVDR beamformer. But this method was not continuously tracking the target speech. Rohdenburg, Hohmann, and Kollmeier (2007) found that these methods showed good performance to reduce diffused or ambient noise but low performance to reduce babble noise (Rohdenburg, Goetze, Hohmann, Kammeyer, & Kollmeier, 2008). The approach of Rohdenburg et al. (2007) was not referred to wide band applications. Although it was advantageous, the computational cost of this technique was high.

Noise Reduction Using Digital Signal Processing Strategies

Strategies in experimental stage

Wavelet based noise reduction The speech signal consists of many frequency components; generally it is complex in nature to understand and to process. Mathematical approach can be followed for analyzing them. A complicated signal can be broken down into simple waves using Fourier Transforms (FT). Fourier Transform analyses only stationary signals, but speech is not a stationary signal. Thus for analyzing non-stationary signals Wavelet Transform (WT) is advantageous because they are fast. Another advantage is that wavelets are represented both in time and frequency domain whereas Fourier transform is a frequency domain representation.

Wavelet-based Maximum likelihood estimation of signals in autoregressive noise method by the approach of Kay and Nagesha (1994) is used for reducing correlated noise in noisy speech signals. Many of the Digital Signal Processing methods have the difficulty in distinguishing between noise and consonants so that most of the consonants are removed along with noise, which reduces the intelligibility of speech. Wavelet-based noise reduction and compression approach by Trenas, Rutledge, and Whitmal (1999) gives solution to this issue. It is flexible as the parameters can be modified to fit the hearing loss of the individual and also the noise characteristics. The response time is less and the accuracy

is good. Therefore in general, Wavelet-based noise reduction approach is highly reliable compared to Fourier Transform technique.

Blind Source Separation (BSS) Blind Source Separation method takes the combination of audio signals, filters them and gives separate output for those signals which are present in that combination. It uses multiple microphones for its operation and assumes that there would be at least as many microphones as the number of sources. One source must be Gaussian and then Independent Component Analysis (ICA) can be used to retrieve the original source signal (Buchner, Aichner, & Kellermann, 2005). The output of the BSS will not have the localization cues. (Kocinski, 2008; Parikh, & Anderson, 2011). BSS algorithm with Wiener filter or Adaptive filters are used for retaining localization cues. BSS combined with adaptive interference cancellation was introduced by Aichner, Buchner, Zourub, and Kellermann (2007) for preserving spatial information. This scheme is powerful if it was for a known scenario. For the unknown scenario, directional BSS and Wiener filtering were combined. Advantage of Directional BSS over BSS is that a good interference estimate can be achieved quickly even with a small number of microphones (Reindl, Zheng, & Kellermann, 2010).

The new BSS algorithm developed by Hild, Ergogmus, and Príncipe (2001) has been reported to be very efficient. Computationally this method is more complex than the rest. Techniques for separating out the acoustic signal in BSS can be divided into two classes, i.e. frequency and time-domain techniques. The time-domain BSS technique (Buchner, Aichner, & Kellermann, 2005) is applied for sound source localization. The BSS-based method outperforms other known techniques, most notably in high reverberant environments. Interestingly, the approach remains applicable in the underdetermined case, where there are more sources than microphones.

Strategies implemented in current hearing aids

Modulation based digital noise reduction (MB-DNR) This technique is widely implemented in hearing aid signal processing to reduce noise. The envelope of the speech signal is amplitude modulated as a result of the vocal tract movements associated with speaking. Modulation rates of 4 Hz to 16 Hz are important for sentence recognition (Drullman, Festen, & Plomp, 1994). Environmental noises are either unmodulated or have a rate of modulation beyond the 4 Hz to 16 Hz range. The signals which are steady are nothing but noise and signal which is modulated more are speech-like (Van, Festen, & Plomp, 1991). The detection and analysis unit recognizes the presence of noise if rate of modulation is beyond the 4 Hz to 16 Hz range.

In MB-DNR, signal is passed through different frequency filters. During filtering, if any output is less modulated, that contains more noise component, the gain of that channel is compressed and channel with speech-like modulation is passed. This may reduce the level of particular frequency speech components, but increases the overall speech to noise ratio. (SNR).

Multichannel wiener filter (MWF) This is basically a modified form of Wiener filter introduced by Doclo and Moonen (2002) to enhance the desired signal reaching from any arbitrary direction. MWF is widely used in binaural hearing aid technology for noise reduction. This method gives a Minimum Mean Square Error (MMSE) estimate of the speech component in the signal received from one of the microphones (Spriet, Moonen, & Wouters, 2002). In binaural hearing aids, the noise reduction can be done by MWF and MWF with partial noise estimate (MWF-N). These methods preserve Inter-aural Time Difference (ITD) and Inter-aural Level Difference (ILD) which enhances the S/N ratio. A famous technique in MWF is Speech Distortion Weighted MWF (SDW-MWF) which can adapt to various noise scenarios. SDW-MWF does not require any assumptions about the location of target speech and characteristics of microphone, unlike the Generalized Sidelobe Canceller (GSC). Doclo, Spriet, Wouters, and Moonen (2007) proposed implementation of the SDW-MWF in frequency domain. It is advantageous that every frequency bin can be processed separately. When compared with Adaptive Directional Microphones (ADM), MWF offers good speech localization (Bogaert, Doclo, Wouters, & Moonen, 2008). Perceptual tests on SDW-MWF and MWF-N showed that transmitting only one channel to the contralateral

hearing aid is enough to ensure good noise removal (Bogaert, Doclo, Wouters, and Moonen, 2009) and the noise localization cue is lost in SDW-MWF and preserved in MWF-N. Li, Sakamoto, Hongo, Akagi, and Suzuki (2011) proposed a two-stage processing and Wiener filter. The two stages were designed for equalization and cancellation of the target signal to get a noise estimate, this noise estimate gives the parameters of the Wiener filter. This technique dominates other spectral subtraction and beamforming approaches and retains the localization cues of the target signal

Scene analysis method Scene analysis approaches are characterized by the use of measurements taken from the input signal to compute a set of frequency responses that are used to filter out the noise. Individuals with hearing impairment find difficulty in separating out speech content of interest amidst interfering sounds, background noise and reverberation. Speech segregation algorithms seek to improve the intelligibility of a desired speech source by attenuating unwanted sounds (Wang & Brown, 2006). It is necessary for human listeners to differentiate and isolate the desired speech through auditory scene analysis. But, it is not enough to recognize the target signal coming from front for scene analysis. A Direction of Arrival (DoA) strategy was proposed by Chisaki, Matsuo, Hagiwara, Nakashima, and Usagawa (2007). In Chisaki's method DoA of target is estimated by the Interaural Time Difference (ITD) and the Interaural Level Difference (ILD) of the input signals. The head related transfer function (HRTF) corresponding to the estimated DoA is used as frequency response to perform the filtering. But there is ambiguity in ILD and DoA relation, this leads to ambiguous DoA estimation.

Table 2: Performance comparison of multiple microphone noise reduction techniques

Parameter	Two microphones	Three microphones	Adaptive Beamforming
SNR for subjects with hearing loss	<ul style="list-style-type: none"> • 3 dB improvement in moving noise • 4 dB improvement in stationary noise (Bentler et al., 2004) 	<ul style="list-style-type: none"> • 4 dB improvement in moving noise • 5 dB improvement in stationary noise (Bentler et al., 2004) 	Two stage adaptive beam-former always performed with better SNR than the adaptive directional microphone (Maj, Royackers, Wouters, & Moonen, 2005)
Average Directivity Index	4.5 to 6.0 dB (Bentler et al., 2004; Powers and Hammacher, 2002)	6.5 to 7.8 dB (Bentler et al., 2004; Powers and Hammacher, 2002)	Significantly higher sequential Directivity Index (sDI) values compared to dual microphone system (Herbig & Froehlich, 2015)

Table 3: Digital noise reduction techniques - Comparison of merits and limitations

Wavelet Based noise reduction	Modulation Based Digital Noise Reduction	Multichannel Wiener Filter	Blind Source Separation	Scene Analysis method
MERITS				
Flexible as the parameters can be modified to fit the hearing loss of the individual and also the noise characteristics. The response time is less and the accuracy is good.(Trenas et al., 1999)	Several Hearing Impaired listeners improved intelligibility from scores near zero to values above 70%.(Healy, Yoho, Wang, & Wang, 2013)	Binaural cues of both the speech and the residual noise should also be better preserved. (Cornelis, 2011)	Optimization of outcome leading to better SNR (Shanmugapriya, & Chandra, 2014)	Capable of separating and identifying the contents of a target utterance in the presence of another speech utterance or speech-shaped noise. (Shao et al., 2010)
LIMITATIONS				
Computationally expensive and require excessive battery power	Interfering signals with speech-like modulation properties could not be reduced.	Assumes that the speech and noise are uncorrelated	Highly complicated to solve and computationally more expensive	Assumes that the target signal is in-phase at both sides, which is not true due to shadow effect.

Li, Akagi, and Suzuki (2008) proposed a method which estimates the noise signal by left and right microphones, and then noise is subtracted from the input signal to get the enhanced speech signal for both ears. But this needs target signal to be in phase for both ears. Later Kamkar and Bouchard (2009) proposed a method which uses coherence function to estimate a frequency response to cancel interference and noise. Shao, Srinivasan, Jin and Wang (2010) proposed a method based on Computational Auditory Scene Analysis (CASA) system for differentiating desired speech from noise. They estimated input speech signal, in two stages. In the first stage, voiced portions of individual sources in each time frame were separated out using harmonicity. Onset/offset analysis was used to segment the unvoiced regions. Speaker characteristics were used to group the Time-Frequency units across time frames, in the second stage. The resulting masks were used for automatic speech recognition. The proposed system was found to be capable of separating and identifying the contents of a target utterance in the presence of another speech utterance or speech-shaped noise.

Results and Discussion

In Table 2, all the three multiple microphone techniques which are currently used for noise reduction in hearing aids are compared on the basis

of two parameters- SNR and Directivity Index. As evident from the Table 1, adaptive beamforming technique is found to be superior as it showed better SNR and higher sDI. The limitation of adaptive beamforming is that, for its efficient performance, the noise sources need to be restricted in number as well as the noise sources need to be directional. A system which has M microphones can control only noises from M-1 noise sources and if the number exceeds M, then the efficiency of noise reduction reduces. Generally, as only one sound source will be dominating in a band of frequency, this drawback will not have much impact in practical situations. Another major deficit of adaptive beamforming arises out of the reverberation in the environment. Greenberg and Zurek(1992)showed empirically that with increase in reverberation time of the listening environment, the efficiency of adaptive beamforming reduces. This issue needs to be addressed by increasing the temporal length of the adaptive filter.

Table 3 compares the merits and limitations of various digital signal processing strategies employed for noise control in hearing aids. The parameters of Wavelet based noise reduction can be modified to suit the hearing loss of the user. Moreover the technique is accurate and the system works very fast. But they are extremely computationally expensive and require excessive battery power, hence not implemented in current hearing aids. These algorithms are experimental, designed for possi-

ble hearing aid related applications. Scene analysis method is capable of separating out a desired speech by isolating the undesired speech, through which a major limitation of the modulation based strategy is overcome. This method is easy to implement and are not computationally expensive and thus figure out to be the best strategy. The wavelet method is very fast and accurate. Scene analysis method assumes that the target signal is in-phase at both sides, which is not true for all frequencies and direction of arrivals due to the head shadow effect. Wavelet based method doesn't have any such limitation and hence if the computational expense and the battery power drain can be controlled, this may be a better option.

Conclusions

Among the three multiple microphone techniques which are currently used for noise reduction in hearing aids, adaptive beamforming technique is found to be superior as it showed better SNR and higher sDI. The limitation of adaptive beamforming is that, for its efficient performance, the noise sources need to be restricted in number as well as the noise sources need to be directional. Also, with increase in reverberation time of the listening environment, the efficiency of adaptive beamforming reduces. This issue needs to be addressed by the designers. Among the various digital signal processing strategies employed for noise control in hearing aids, scene analysis method was found to be the best strategy. Wavelet based noise reduction, which has been experimented over the years, is considered to be a better option compared to the scene analysis method, provided its limitations such as higher computational expense and battery drain are properly addressed. This needs to be brought to the notice of hearing aid designers.

Conflict of Interest: NIL

Source of Funding: NIL

References

- Abrams, H. B., & Kihm, J. (2015). An Introduction to MarkeTrak IX: A New Baseline for the Hearing Aid Market. *Hearing Review*, 22(6), 16.
- Aichner, R., Buchner, H., Zourub, M., & Kellermann, W. (2007). Multi-channel source separation preserving spatial information. *IEEE International Conference on Acoustics, Speech and Signal processing*, doi: 10.1109/ICASSP.2007.366602
- Beck, D. L., & Behrens, T. (2016). The Surprising Success of Digital Noise Reduction. *Hearing Review*, 23(5), 20.
- Bentler, R. A., Palmer, C., & Dittberner, A. B. (2004). Hearing in noise: Comparisons of listeners with normal and (aided) impaired hearing. *Journal of the American Academy of Audiology*, 15(3), 216-225.
- Bentler, R. A. (2005). Effectiveness of Directional Microphones and Noise Reduction Schemes in Hearing
- Aids: A Systematic Review of the Evidence. *Journal of the American Academy of Audiology*, 16(7), 473-484.
- Bogaert, Van den T., Doclo, S., Wouters, J., & Moonen M. (2009). Speech enhancement with multichannel Wiener filters techniques in multimicrophone binaural hearing aids. *The Journal of the Acoustical Society of America*, 125(1), 360-371.
- Bogaert, Van den T., Doclo S., Wouters, J., & Moonen, M. (2008). The effect of multi microphone noise reduction systems on sound source localization by users of binaural hearing aids. *The Journal of the Acoustical Society of America*, 124(1), 484-497.
- Buchner, H., Aichner, R., & Kellermann, W. (2005). A generalization of blind source separation algorithms for convolutive mixtures based on second-order statistics. *IEEE Transactions on Speech and Audio Processing*, 13(1), 120-134.
- Chisaki, Y., Matsuo, K., Hagiwara, K., Nakashima, H., & Usagawa, T. (2007). Real-time processing using the frequency domain binaural model. *Applied Acoustics*, 68(8), 923-938.
- Chung, K. (2004). Challenges and Recent Developments in Hearing Aids: Part I. Speech Understanding in Noise, Microphone. *Trends in Amplification*, 4(8), 83-124
- Cornelis, B. (2011). *Design and evaluation of noise reduction techniques for binaural hearing aids*. Unpublished Phd. Thesis, Katholieke University, Leuven. Online access at ftp://ftp.esat.kuleuven.be/sista/bcorneli/thesis/phd_Cornelis.pdf
- Dell'Antonia, S. F., Ikino, C. M. Y., & Filho, C. W. (2013). Degree of satisfaction of patients fitted with hearing aids at a high complexity service. *Brazilian Journal of Otorhinolaryngology*, 79(5), 555-563.
- Doclo, S., & Moonen, M. (2002). GSVD-based optimal filtering for single and multi microphone speech enhancement. *IEEE Transactions On Signal Processing*, 50(9), 2230-2244.
- Doclo, S., Spriet, A., Wouters, J., & Moonen, M. (2007). Frequency-domain criterion for speech distortion weighted multichannel wiener filter for robust noise reduction. *Speech Communication*, 49(7-8), 636-656.
- Drullman, R., Festen, J. M., & Plomp, R. (1994). Effects of reducing slow temporal modulations on speech reception. *Journal of the Acoustical Society of America*, 95(5), 2670-2680.
- Greenberg, J.E., & Zurek, P.M (1992). Evaluation of an adaptive beamforming method for hearing aids. *The Journal of the Acoustical Society of America*, 91(3), 1662-76.
- Griffiths, L., & Jim, C. W. (1982). An alternative approach to linearly constrained adaptive beamforming. *IEEE Transactions on antennas and propagation*, 30(1), 27-34.
- Healy, E. W., Yoho, S. E., Wang, Y., & Wang, D. (2013). An algorithm to improve speech recognition in noise for hearing-impaired listeners. *The Journal of the Acoustical Society of America*, 134(4), 3029-38.
- Herbig, R., & Froehlich, M. (2015). Binaural Beamforming: The Natural Evolution. *Hearing Review*, 22(5), 24.
- Hild, K.E., Erdogmus, D., & Principe, J. (2001). Blind Source Separation Using Renyi's Mutual Information. *IEEE Signal Processing Letters*, 8(6), 174-176.
- Kamkar-Parsi, A., & Bouchard, M. (2009). Improved noise power spectrum density estimation for binaural hearing aids operating in a diffuse noise field environment. *IEEE Transactions on Audio, Speech, and Language Processing*, 17(4), 521-533.
- Kay, S., & Nagesha, V. (1994). Maximum likelihood estimation of signals in autoregressive noise. *IEEE Transactions on Signal Processing*, 42(1), 88-101.
- Kocinski, J. (2008). Speech intelligibility improvement using convolutive blind source separation assisted by de-

- noising algorithms. *Speech Communication*, 50(1), 29-37.
- Kompis, M., & Dillier, N. (2001). Performance of an adaptive beamforming noise reduction scheme for hearing aid applications. I. Prediction of the signal-to-noise-ratio improvement. *The Journal of the Acoustical Society of America*, 109 (3), 1123-1133.
- Levitt, H. (2001). Noise reduction in hearing aids: a review. *Journal of Rehabilitation Research and Development*, 38(1), 111-121.
- Li, J., Akagi, M., & Suzuki, Y. (2008). Extension of the two-microphone noise reduction method for binaural hearing aids. *International Conference on Audio, Language and Image Processing*. doi: 10.1109/ICALIP.2008.4590071
- Li, J., Sakamoto, S., Hongo, S., Akagi, M., & Suzuki, Y. (2011). Two-stage binaural speech enhancement with Wiener filter for high-quality speech communication. *Speech Communication*, 53(5), 677-689.
- Lotter, T., & Vary, P. (2006). Dual-channel speech enhancement by super-directive beam forming. *EURASIP Journal on Advances in Signal Processing*, 1, 1-14, doi: 10.1155/ASP/2006/63297
- Ngo, K. (2011). *Digital signal processing algorithms for noise reduction, dynamic range compression, and feedback cancellation in hearing aids*. (Doctoral dissertation). Retrieved on June 7, 2017, from [ftp://ftp.esat.kuleuven.be/sista/kngo/reports/phd.KimNgo.pdf](http://ftp.esat.kuleuven.be/sista/kngo/reports/phd.KimNgo.pdf)
- Nishimura, R., Suzuki, Y., Tsukui, S., & Asano, F. (2004). Array signal processing with two outputs preserving binaural information. *Applied acoustics*, 65(7), 657-672.
- Parikh, D., & Anderson, D. (2011). *Blind source separation with perceptual post processing*. Digital Signal Processing Workshop and IEEE Signal Processing Education Workshop (DSP/SPE), doi: 10.1109/DSP-SPE.2011.5739233
- Park, H. S., Moon, I. J., Jin, S. H., Choi, J. E., Cho, Y. S., & Hong, S. H. (2015). Benefit from directional microphone hearing aids: objective and subjective evaluations. *Clinical and Experimental Otorhinolaryngology*, 8(3), 237.
- Powers, T.A., Hamacher, V. (2002). Three-microphone instrument is designed to extend benefits of directionality. *Hearing Journal*, 55(10), 38-45
- Ramirez, Patricia., Jons, Catherine., & Powers, Thomas A. (2013). Optimizing Noise Reduction Using Directional Speech Enhancement. *Hearing Review*, 11(7), 14-18
- Reindl, K., Zheng, Y., & Kellermann, W. (2010). *Speech Enhancement for Binaural Hearing Aids based on Blind Source Separation*. IEEE 4th International Symposium on Communications, Control and Signal Processing, doi: 10.1109/ISCCSP.2010.5463317
- Rohdenburg, T., Goetze, S., Hohmann, V., Kammeier, F. D., & Kollmeier, B. (2008). *Objective perceptual quality assessment for self-steering binaural hearing aid microphone arrays*. IEEE International Conference on Acoustics, Speech and Signal Processing (pp. 2449-2452).
- Rohdenburg, T., Hohmann, V., & Kollmeier, B. (2007). Robustness analysis of binaural hearing aid beamformer algorithms by means of objective perceptual quality measures. *IEEE Workshop on Applications of Signal Processing to Audio and Acoustics* (pp. 315-318).
- Shanmugapriya, N., & Chandra, E. (2014). A Thorough Investigation on Speech Enhancement Techniques for Hearing Aids. *International Journal of Computer Applications*, 99(13), 9-12.
- Shao, Y., Srinivasan, S., Jin, Z., & Wang, D. (2010). A computational auditory scene analysis system for speech segregation and robust speech recognition. *Computer Speech and Language*, 24, 77-93.
- Spriet, A., Moonen, M., & Wouters, J. (2002). A multichannel sub-band GSVD based approach for speech enhancement in hearing aids. *European Transactions on Telecommunications, Special Issue on Acoustic Echo and Noise Control*, 13(2), 149-158. doi: 10.1002/ett.4460130210
- Trenas, M. A., & Rutledge J.C., & Whitmal III, N. A. (1999). *Wavelet-based noise reduction and compression for hearing aids*. IEEE Proceedings of The First Joint BMES/EMBS Conference Serving Humanity, Advancing Technology. doi: 10.1109/IEMBS.1999.802748
- Van, D. J. N., Festen, J. M., & Plomp, R. (1991). The effect of frequency-selective attenuation on the speech reception threshold of sentences in conditions of low frequency noise. *The Journal of the Acoustical Society of America*, 90(2), 885-894.
- Wang, De Liang., & Brown, Guy J. (2006). *Computational Auditory Scene Analysis: Principles, Algorithms, and Applications*. New York: Wiley-IEEE Press.
- World Health Organization. (2017). *Deafness and Hearing loss*. Retrieved on June 25, 2017, from <http://www.who.int/mediacentre/factsheets/fs300/en>